

NFVとモバイルネットワークの技術動向

情報通信技術分科会 IPネットワーク設備委員会

5G加入数の立上りは4Gを上回る勢い



サービス開始時点からの世界全体の加入数の推移 [単位：百万]

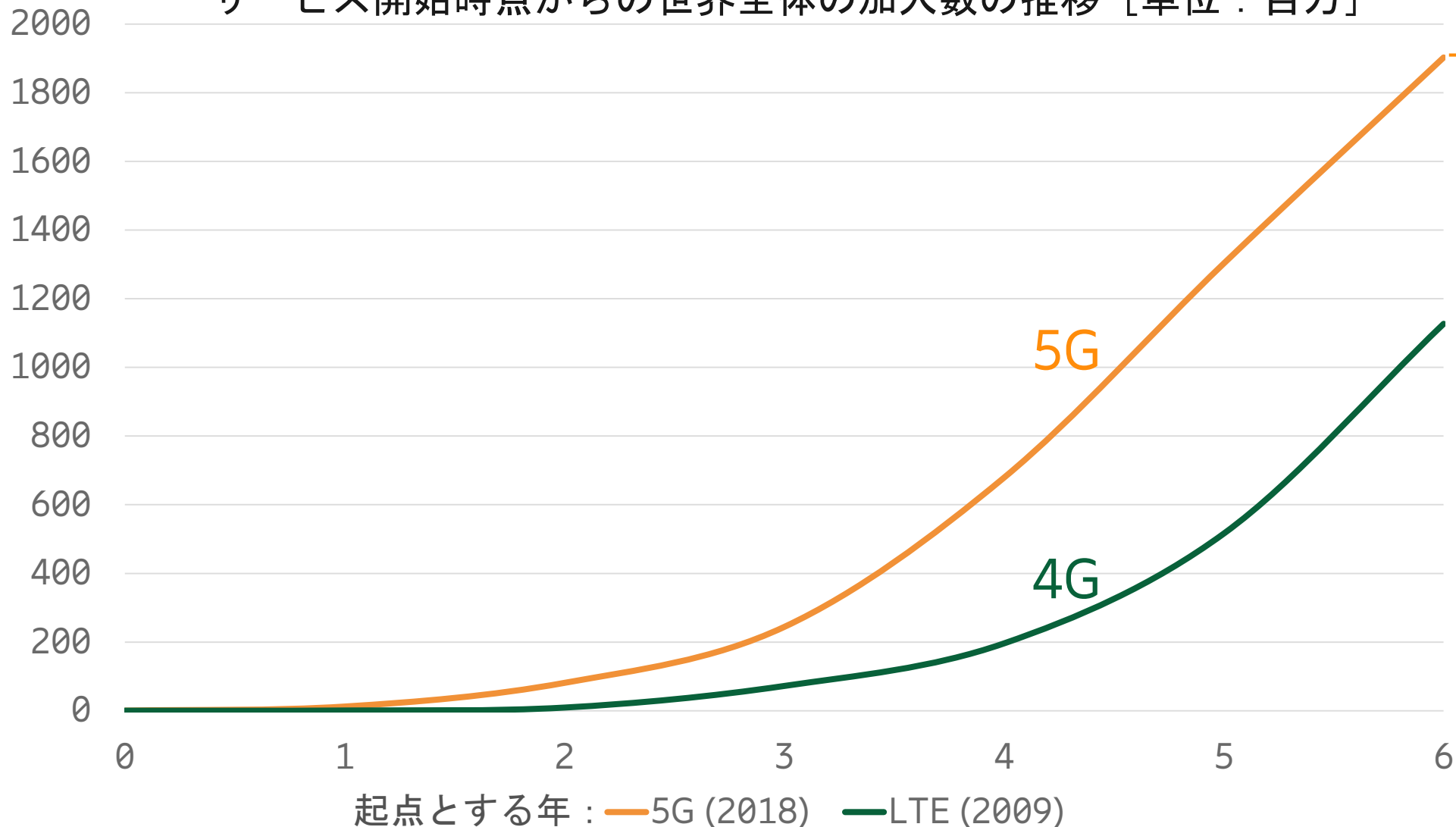

19億

2024年には5G加入が世界で19億に達する見込み

世界のモバイルトラフィック量の推移

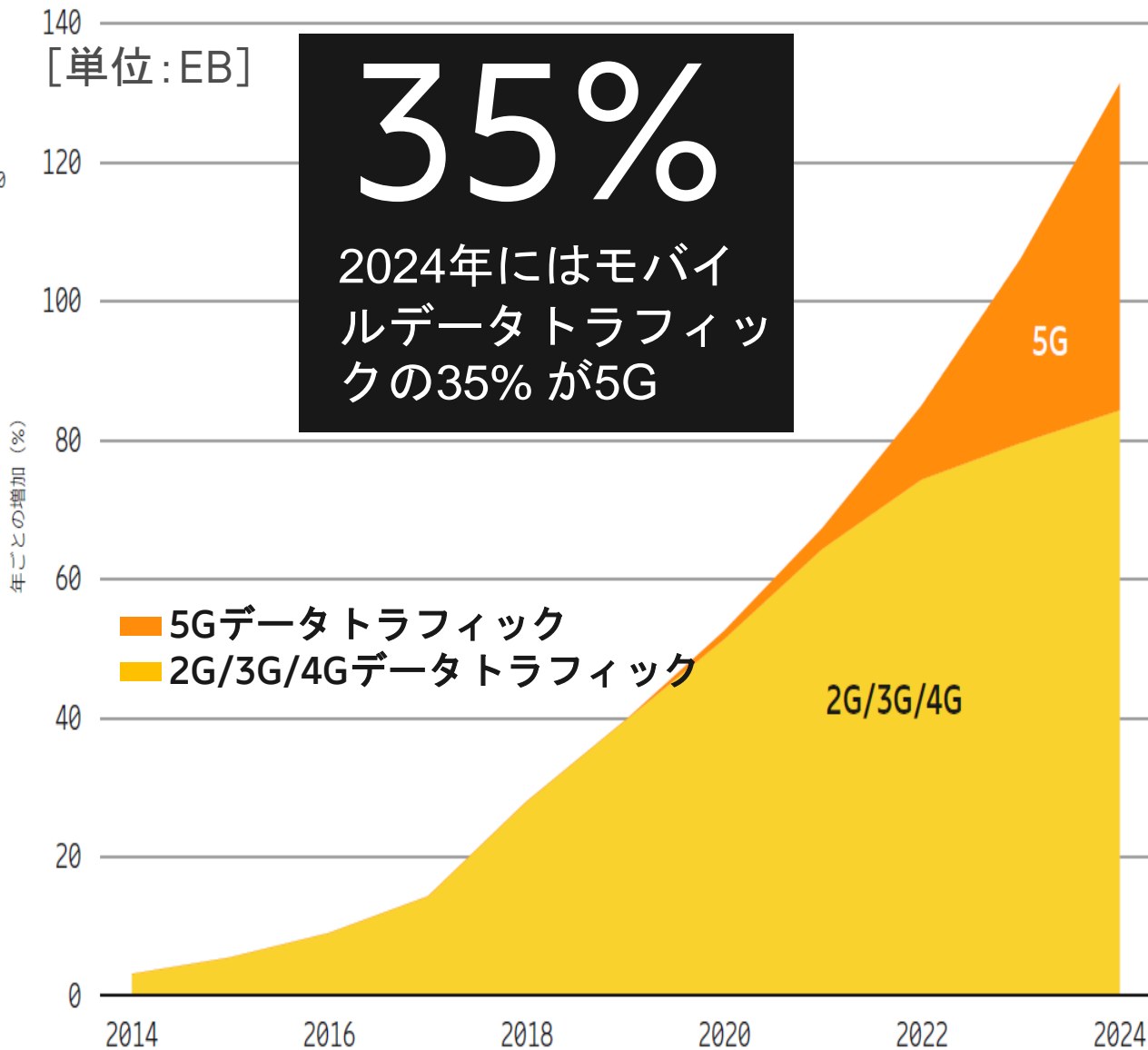
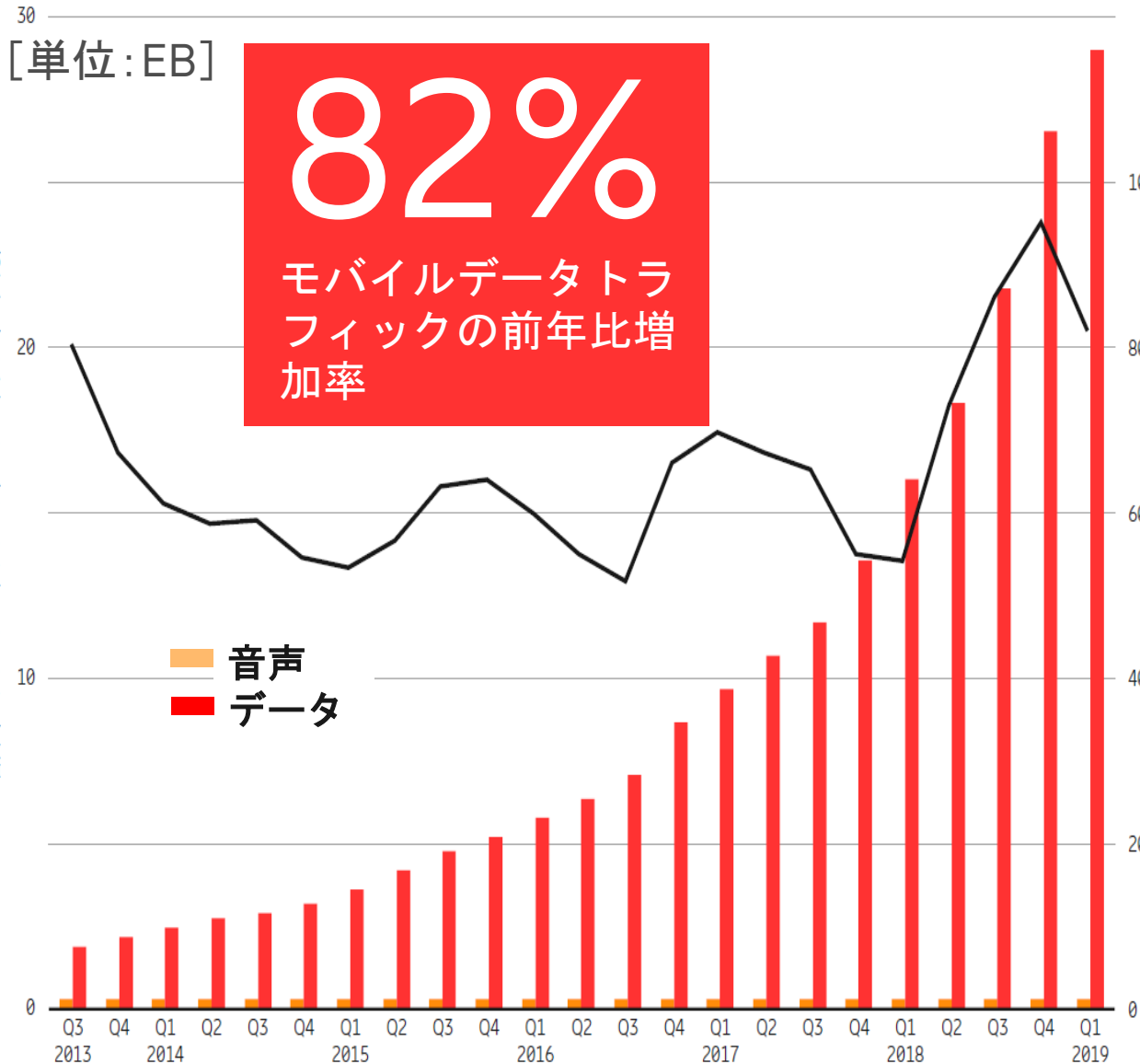

5G use cases

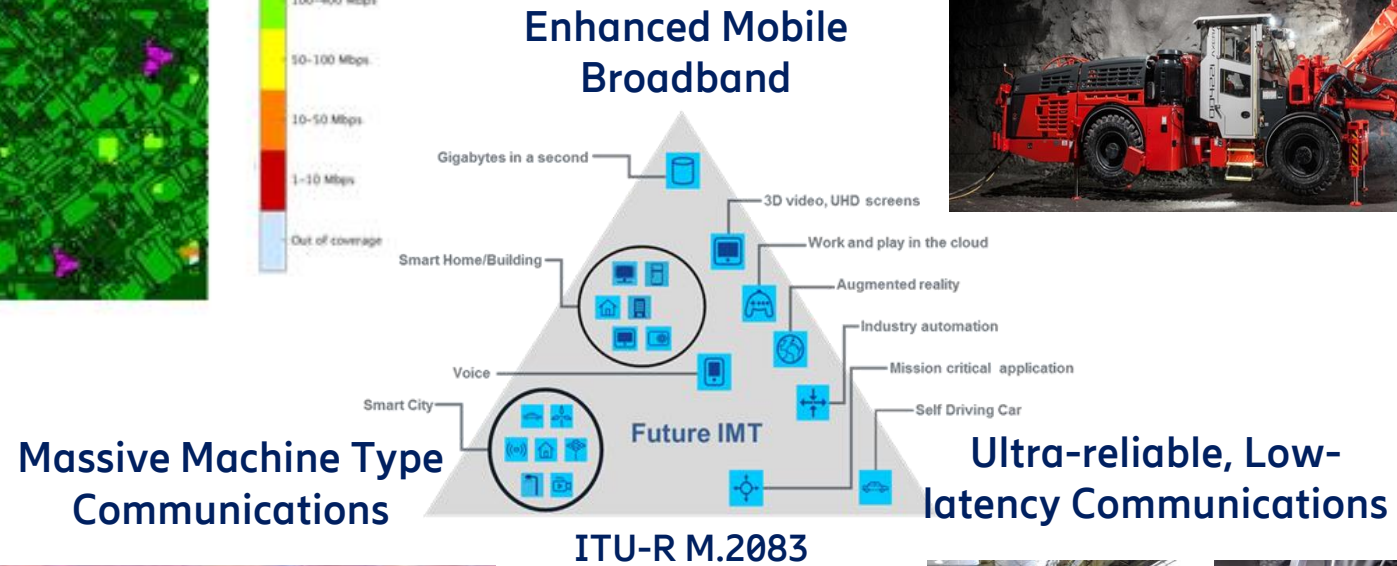
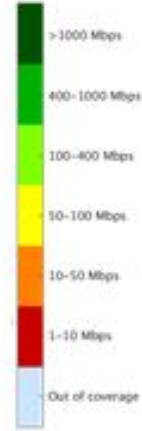
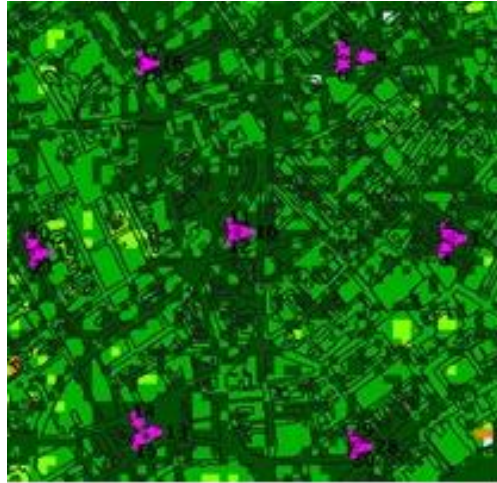

Ericsson 5G commercial live networks



*as of Aug. 13th 2019

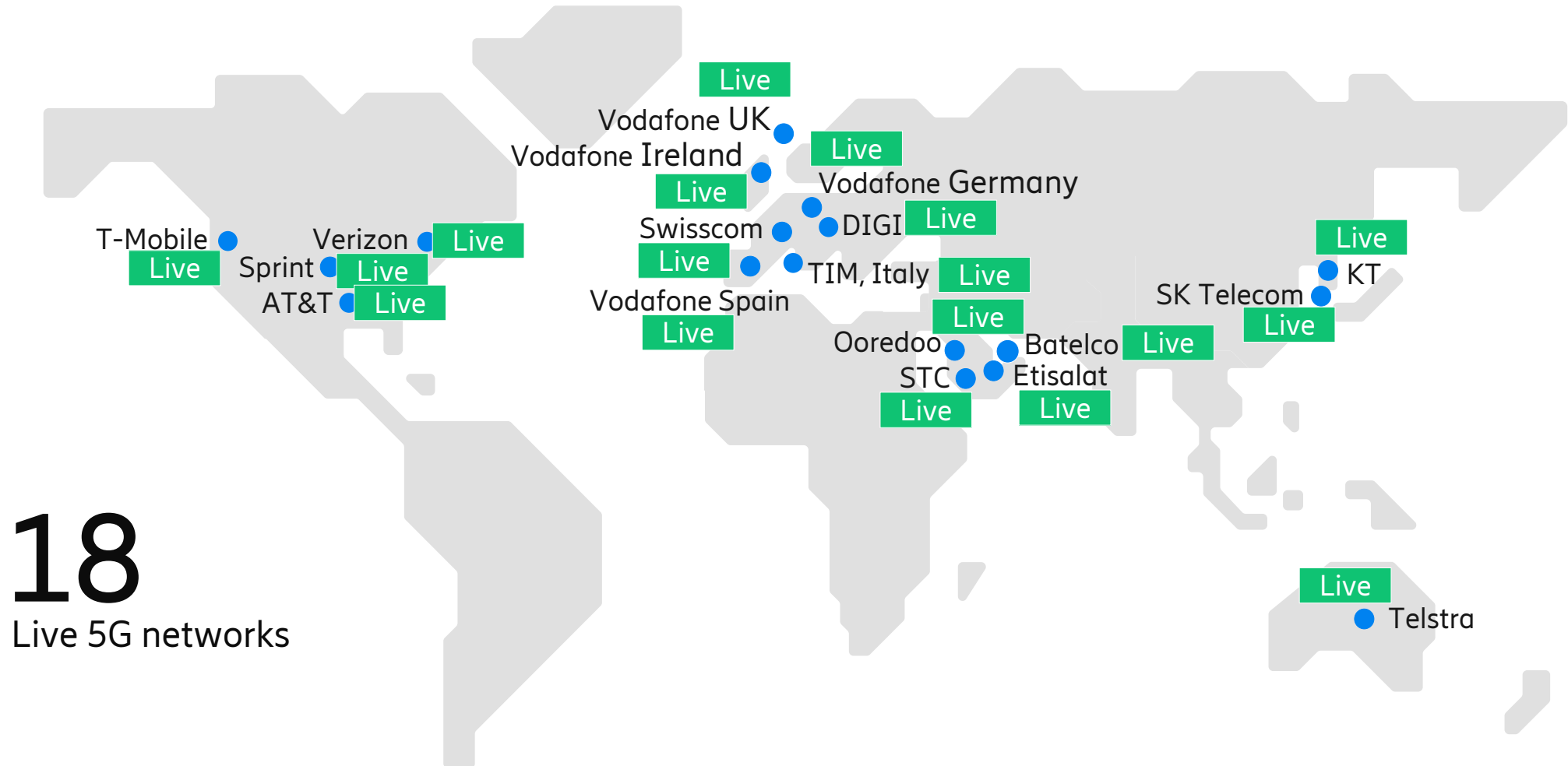

18
Live 5G networks

<https://www.ericsson.com/en/5g/5g-networks/5g-contracts>
<https://www.ericsson.com/en/5g>

2G、3G、4Gネットワーク構成の変化 (3GPP)

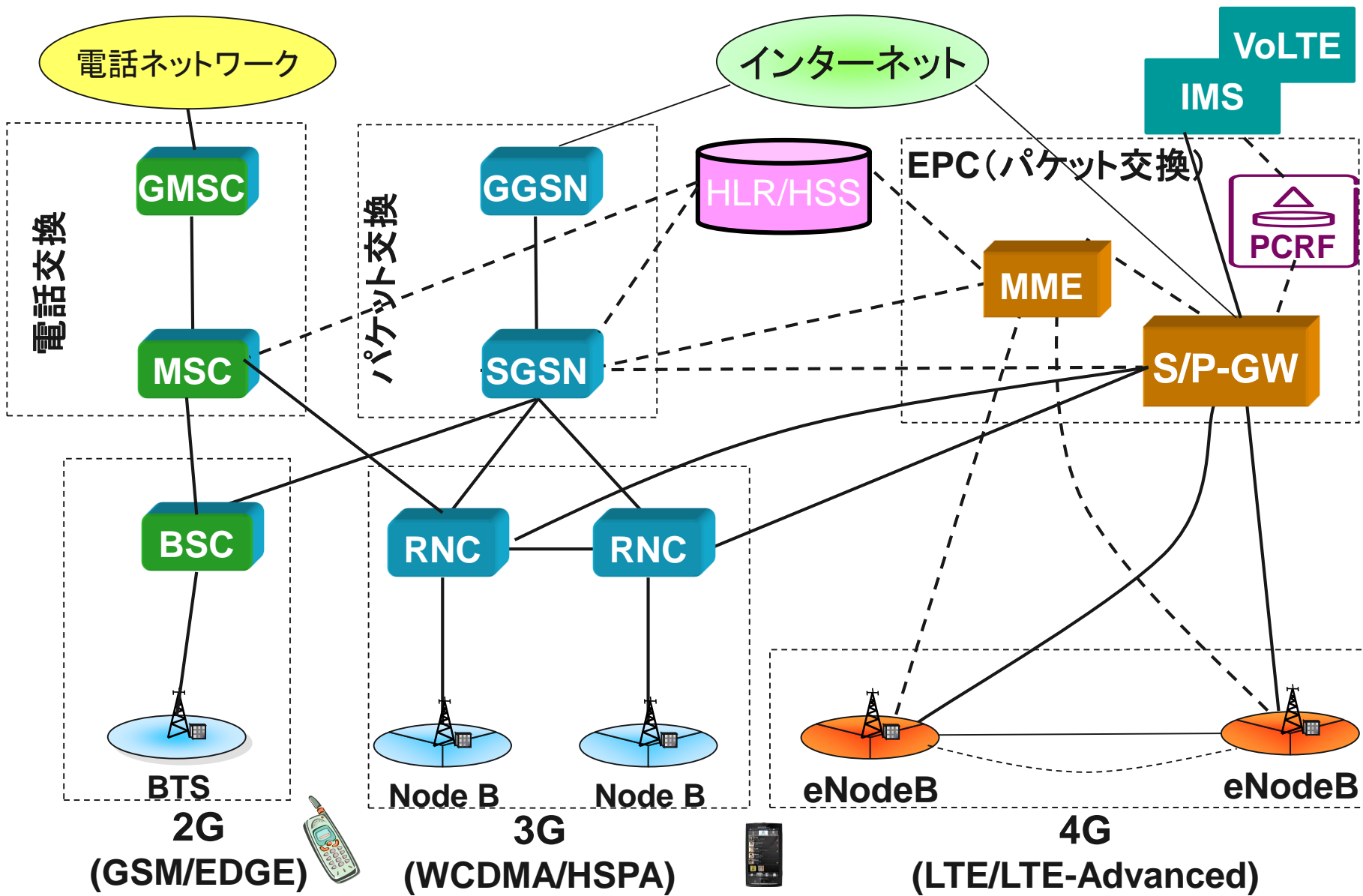

- BSC: Base Station Controller
- BTS: Base Transceiver Station (基地局)
- GMSC: Gateway MSC
- HLR: Home Location Register
- HSS: Home Subscriber Server
- IMS: IP Multimedia Subsystem
- MME: Mobility Management Entity
- MSC: Mobile Switching Center (電話交換機)
- NodeB: 3G基地局
- eNodeB: LTE基地局
- PCRF: Policy & Charging Rules Function
- PDN: Packet Data Network
- S/P-GW: Serving/PDN Gateway (パケット処理装置)
- VoLTE: Voice over LTE

NFV (Network Functions Virtualization)



専用ハードウェアにネットワーク機能実装



Message Router



CDN



Session Border Controller

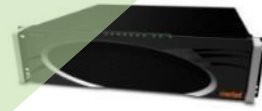

WAN Acceleration



DPI

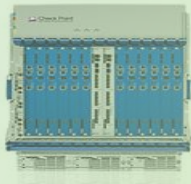

Firewall



Carrier Grade NAT



Tester/QoE monitor



S-GW/P-GW



PE Router



BRAS



Radio Network Controller

ネットワーク機能毎のソフトウェア

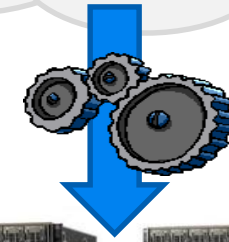
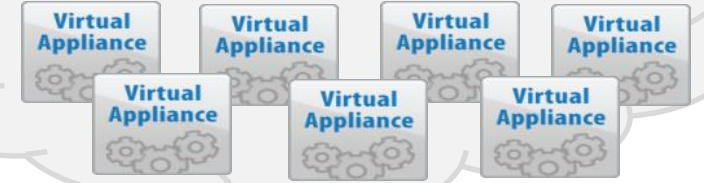

サーバに実装



高処理能力サーバ



大容量ストレージ



大容量スイッチ

仮想化とクラウド化

SDN/NFV technology and Architecture

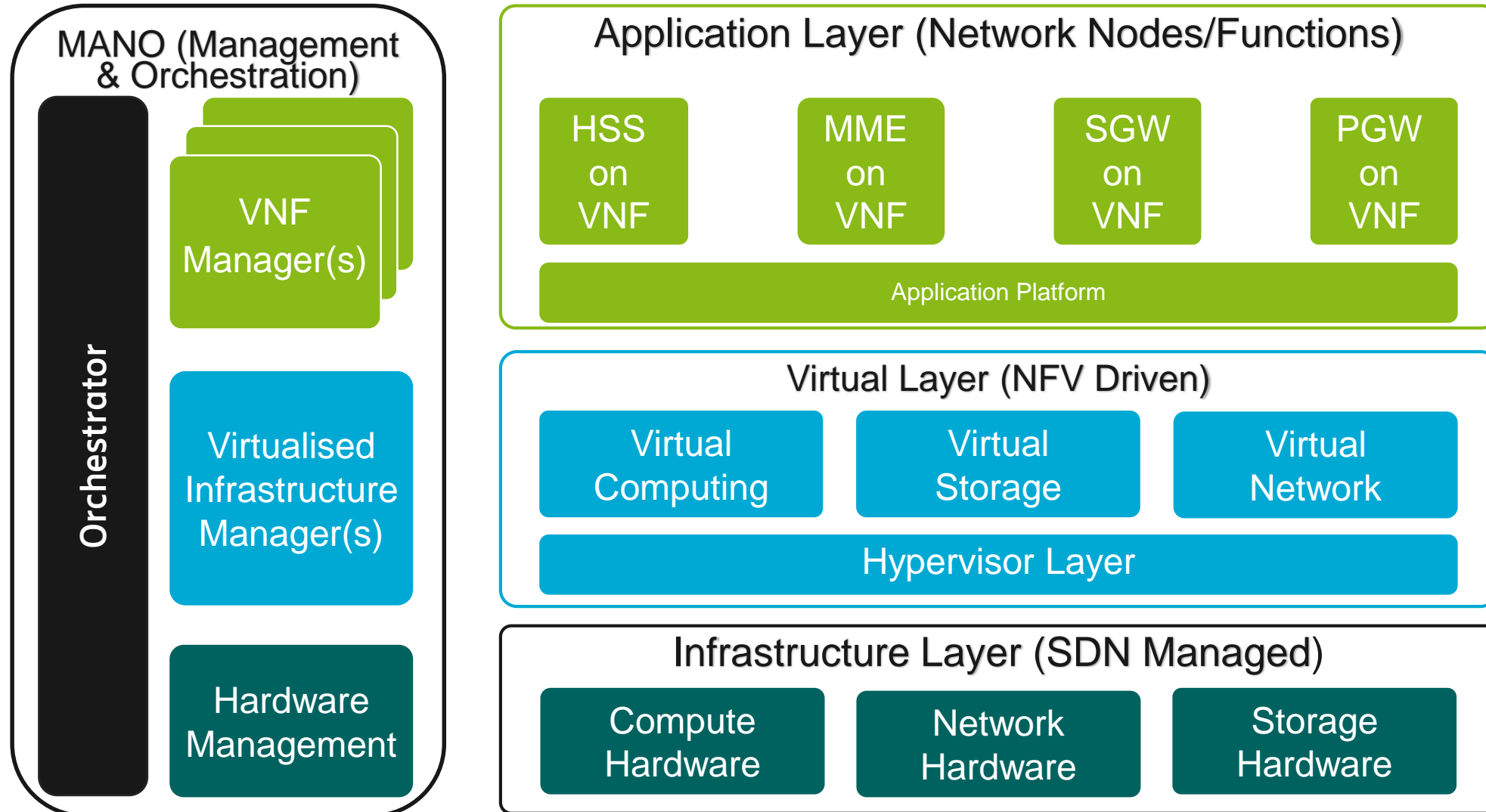

ネットワークアーキテクチャの進化

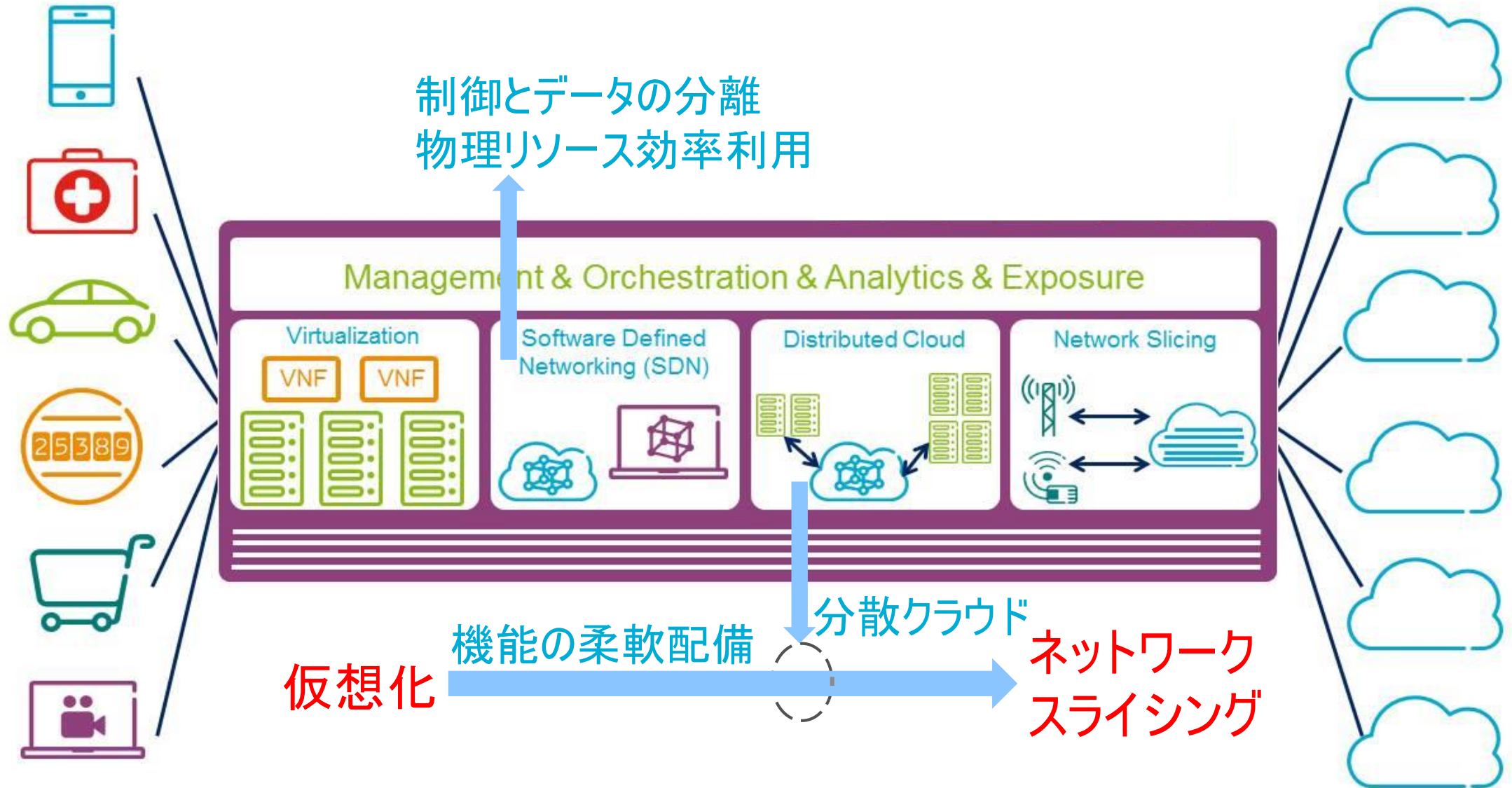

一つのネットワークで様々なユースケース ネットワークスライシング

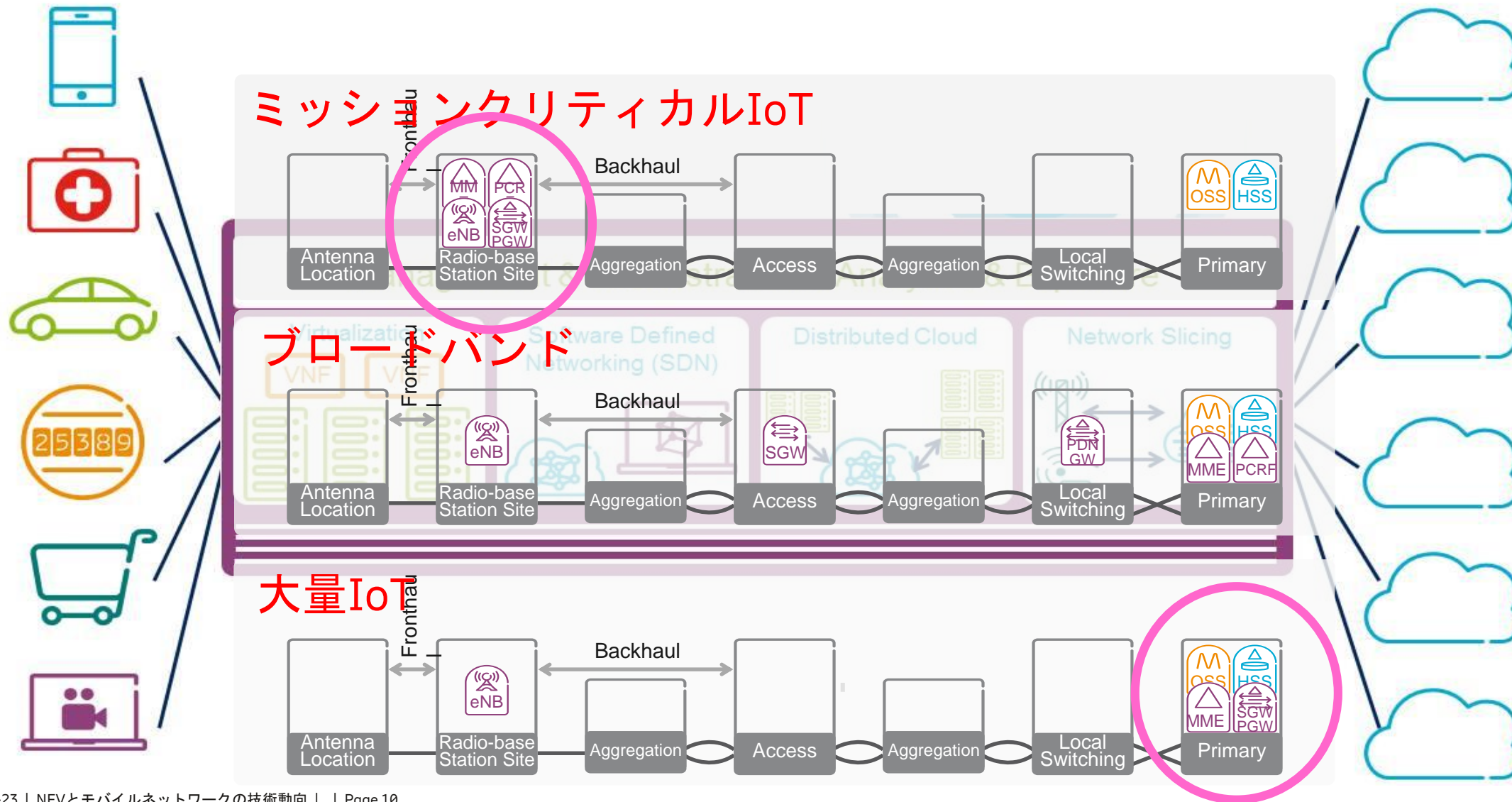

Ericsson NFV references

VNF's, NFVI, NFV-MANO (Updated Q1 2019)

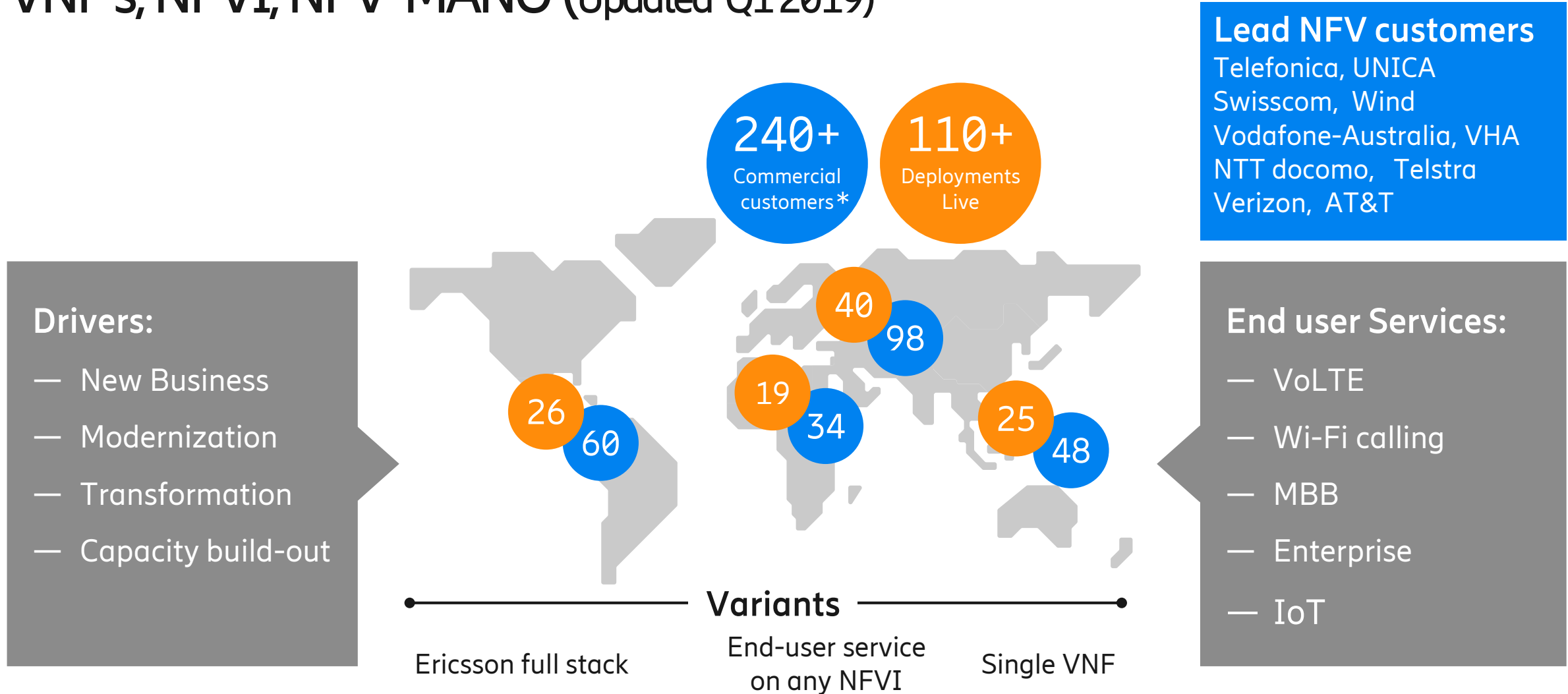

NFVの実装例 (Siwsscom)



Telco Cloud
Vendor
Ecosystem

VNF

ERICSSON
Hewlett Packard Enterprise
HUAWEI
FORTINET
wit software
CISCO
aruba a Hewlett Packard Enterprise company
A10
swisscom

MANO

ERICSSON
Hewlett Packard Enterprise

NFV-I

ERICSSON

Data Center Gateway Connectivity

CISCO
JUNIPER NETWORKS

<https://www.ericsson.com/en/press-releases/2016/2/swisscom-selects-ericsson-for-telco-cloud-infrastructure-and-nfv-of-core-network-functions>

NFVの実装例 (Telefónica)

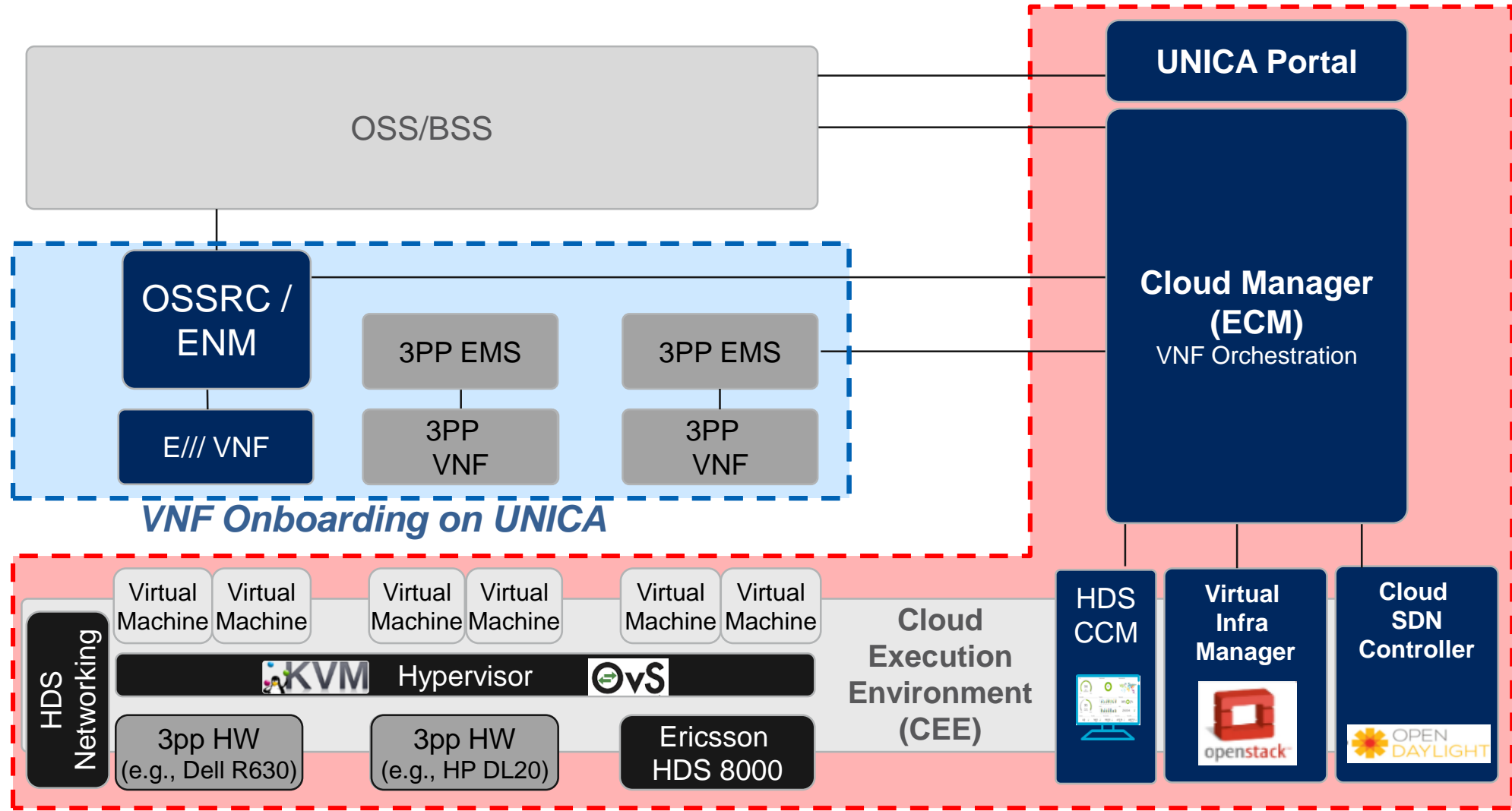

Ericsson Solution

<https://www.ericsson.com/en/press-releases/2016/2/telefonica-selects-ericsson-for-global-unica-program>

NFVの実装例 (Vodafoneオランダ)

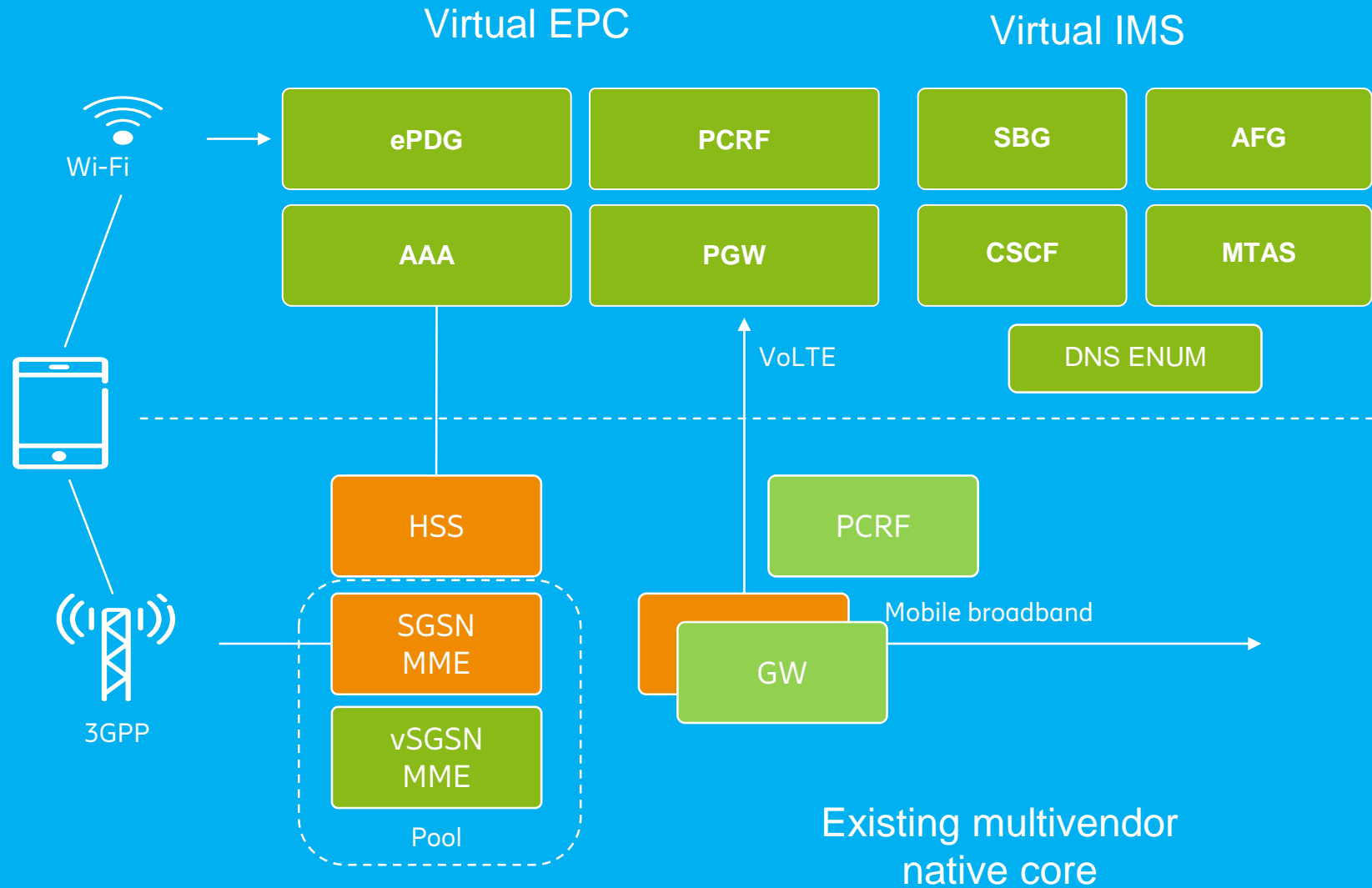

<https://www.ericsson.com/en/press-releases/2016/3/ericsson-and-vodafone-deploy-first-cloud-based-volte-and-wi-fi-calling-in-the-netherlands>

5Gに向けたネットワークの進化

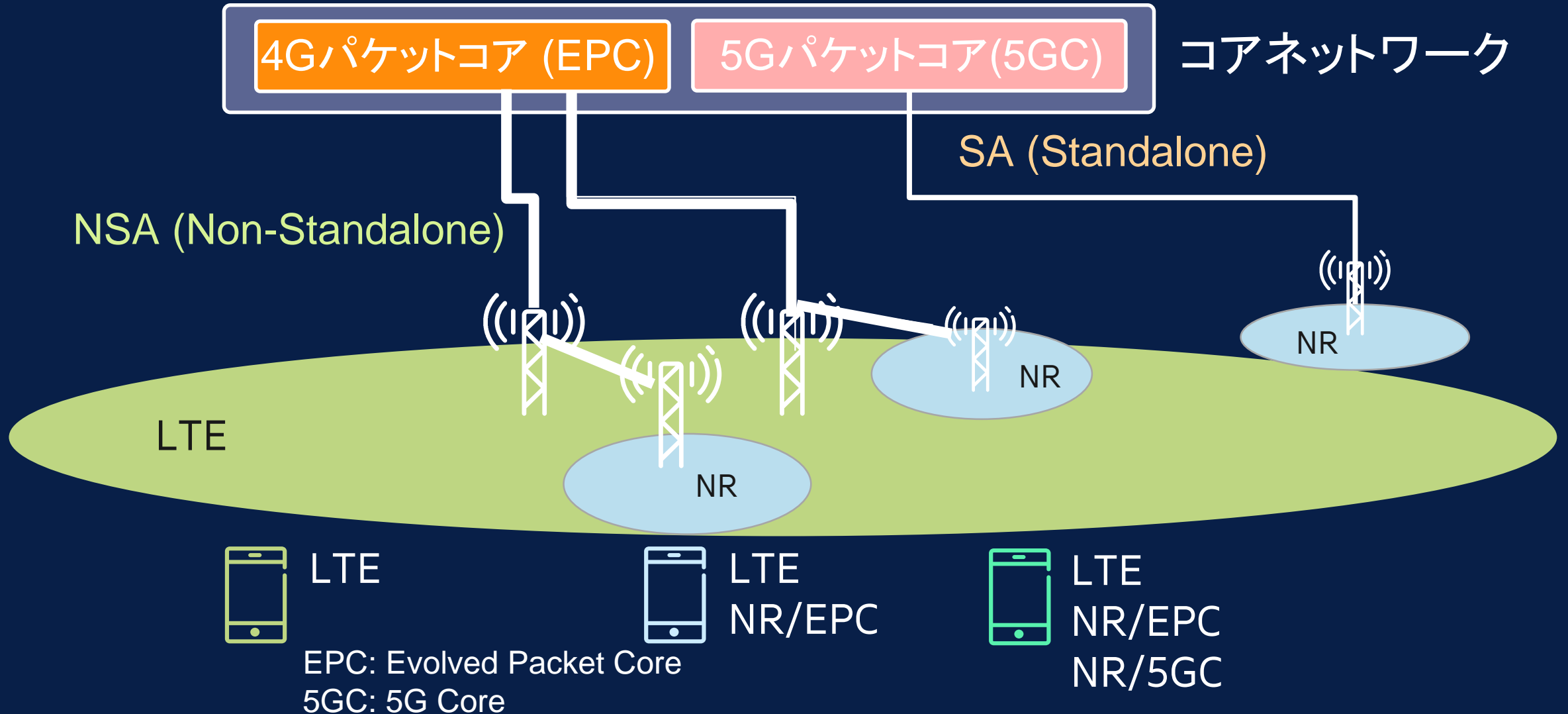

5GC: Service Based Architecture (SBA)

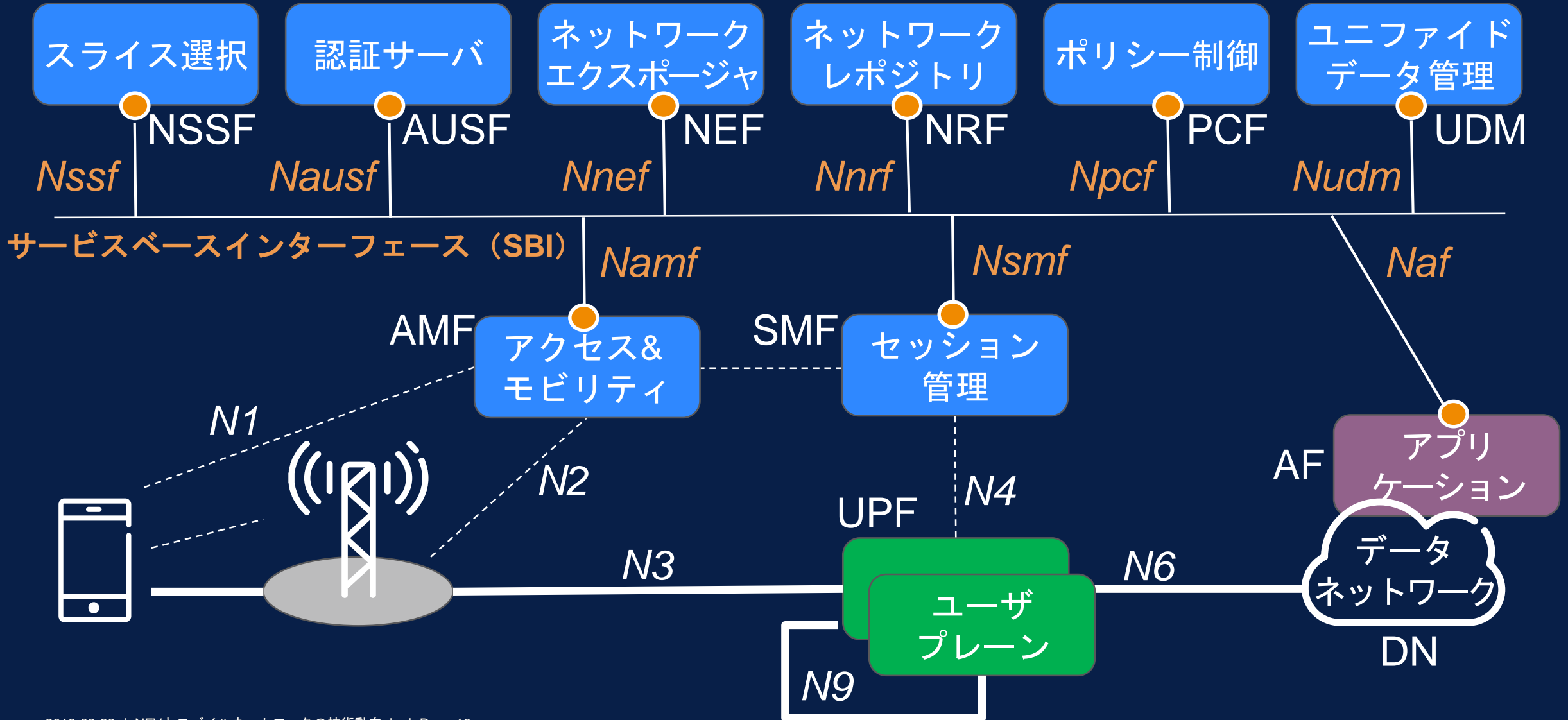

4G/5Gデュアルモードコア

- 一つのコアネットワークで4Gと5Gに対応、運用効率化と柔軟性を確保
- VMベースのEPCからContainerベースのクラウドネイティブなアーキテクチャへの進化をライブデモで実演
- 自動化により保守運用の単純化
- 拡張性と即応性の確保
- NW機能開放/スライシング

